

**NATIONAL  
REBEL CLASS  
ASSOCIATION**

**CONSTITUTION  
AND  
BYLAWS**

**Revised July 14, 2017**

*Allow multiple windows in sails.*

# CONSTITUTION AND BYLAWS

## NATIONAL REBEL CLASS ASSOCIATION

### Constitution

I	Name .....	2
II	Emblem .....	2
III	Object .....	2
IV	Policy .....	2
V	Jurisdiction .....	3
VI	Organization .....	3
VII	Membership Eligibility .....	3
VIII	Association Elected Officers .....	4
IX	District Officers .....	5
X	Board of Directors .....	6
XI	Meetings .....	7
XII	Quorum and Roll Call .....	7
XIII	Voting .....	7
XIV	Expulsion .....	8
XV	Amendments .....	8
XVI	Dissolution .....	8

### Bylaws

I	Dues .....	9
II	Renewal of Charter .....	9
III	Eligible Yachts .....	9
IV	Racing Rules .....	9
V	Racing Restrictions .....	9
VI	Interpretation .....	10
VII	Sanctioned Events .....	10
VIII	Limitation Governing Purchase of Sails .....	11
IX	Class Publication .....	11
X	Specifications .....	11
XI	Amendments to Bylaws .....	16
	Drawings .....	17/21

# **CONSTITUTION**

## **ARTICLE I - Name**

The name of this organization shall be the **NATIONAL REBEL CLASS ASSOCIATION**

## **ARTICLE II - Trademark, Molds, Designs and Royalties**

The trademark of the Rebel Class shall be an "R" as described in the sail plan. The trademark, molds and designs of the Rebel Class sailboat are the sole property of the National Rebel Class Association. To rigidly maintain the one-design features and to ensure availability of newly manufactured boats, the Board of Directors of the National Rebel Class Association may authorize exclusive or non-exclusive manufacture of Rebel Class sailboats at their discretion through a royalty and/or number tax system. The Board of Directors may also institute a royalty system to require sail makers and/or sail owners of new Rebel sails to pay a royalty to the Association for each new sail made. If any of these systems is in place, only those new boats and/or sails on which the royalty and/or number tax has been paid to the National Rebel Class Association will be considered eligible to meet the Specifications of Article X of the Bylaws.

## **ARTICLE III - Object and Purpose**

To promote Rebel Class sailboat racing under uniform rules governed by this Association, and to rigidly maintain and protect the one-design features of the Rebel Class sloop as designed by Ray Greene.

The purpose of the Association shall be charitable and educational, and it is formed and shall operate exclusively to foster national and international amateur sports competition (specifically in the area of sailing in Rebel Class sailboats) with no part of its activities involving the provision of athletic facilities or equipment, all as provided within the meaning of Section 501(c)(3) of the Internal Revenue Code of 1954 as amended.

## **ARTICLE IV - Policy**

To implement the object of the Association it shall be the policy of the Association to:

1. Cooperate with all other yachting organizations and demand in return observance of the rules of the National Rebel Class Association.
2. Keep the Rebel Class within the financial reach of persons of moderate means without handicapping ability nor encouraging neglect in conditioning boats.
3. Rigidly maintain a strictly one-design class in order to insure that all Rebel Class races held under the auspices of this Association be to determine the ability of the skipper. Everything in the Constitution, Bylaws and specifications is intended to insure competition between boats of identical design and the spirit of the Constitution, Bylaws and specifications is to this end.

## **ARTICLE V - Jurisdiction**

The Association shall have jurisdiction over all proper Rebel Class activities.

## **ARTICLE VI - Organization**

1. The Association shall consist of individuals holding active, associate or honorary membership.

2. Individual members shall join a Fleet if possible. The Fleet, a territorial branch or unit, shall be open to all eligible persons within its territory; shall elect its own officers, which must include a Fleet Secretary; shall be self governing in local matters not conflicting with Association rules; and set its own territorial limits.

3. Groups of Fleets in the same geographical area may be organized into Districts by the Board of Directors.

4. The powers of the Association shall be vested in the Board of Directors.

5. The fiscal year of the Association shall coincide with the calendar year.

## **ARTICLE VII - Membership Eligibility**

The membership in the Association shall consist of three Classes: Active, Associate and Honorary.

1. An Active Member must be an owner or part-owner (not less than 25%) of a Rebel Class sailboat, or a representative of a Rebel Fleet organized within any branch of the armed services, and a Corinthian, regardless of age or sex. An Active Member is privileged to hold office, to vote and to skipper a Rebel Class sailboat in sanctioned races, in accordance with the Bylaws. Active Membership shall be retained until the end of the calendar year in which the member ceases to be a Rebel owner.

2. An Associate Member must be a Corinthian and cannot vote or hold office, or skipper in sanctioned events.

3. An Honorary Member must be a non-owner of a Rebel Class sailboat, elected by 2/3 vote of the Board of Directors. An Honorary Member cannot vote, hold office, or skipper a Rebel in sanctioned races.

4. Active Membership in any Fleet shall be restricted to Active Members of the Association. Associate Membership in any Fleet shall be restricted to Associate Members of the Association.

5. A member cannot belong to more than one Fleet unless approved by the Executive Committee of the National Association Board, nor can a Rebel Class sailboat be registered in more than one Fleet.

## **ARTICLE VIII - Association Elected Officials**

Elected officials shall consist of the Executive Officers, eight (8) Fleet Representative members of the Board of Directors and three (3) members of the Class Measuring Committee.

1. Executive Officers shall consist of Commodore, Vice Commodore, Rear Commodore, Secretary, Treasurer, and the immediate Past Commodore. The offices of Secretary and Treasurer may be held by one person, in which case these combined offices will be entitled to one vote on matters before the Board of Directors or the Executive Committee. They shall be elected at the Annual Meeting and National Championship Series and shall serve until the next Annual Meeting or until their successors qualify.

a. The Commodore shall be the chief executive of the Association and Chairman of the Board of Directors. The Commodore presides at all meetings, rules on procedures and jurisdiction, summarizes decisions, appoints special committees, designates the time and place of board meetings and authorizes payment of bills.

b. The Vice Commodore shall officiate in the absence of the Commodore.

c. The Rear Commodore shall be the Chairman of the Rebel Junior Nationals and shall be responsible for ordering, assembly and delivery of all national trophies and chevrons.

d. The Secretary shall handle all correspondence, record minutes, certify national and district fleets, fleet reports, fleet charters, national and district membership rosters, membership reports, Rebel Rabble mailing lists, communication, historical records and action announcements. The secretary shall handle all correspondence concerning the Constitution and Bylaws, shall be the USSA representative and order all stationary and supplies, record all sail numbers and perform all other duties pertaining to such and office.

e. The Treasurer shall deposit funds in a depository approved by the Board of Directors, keep financial records and securities of the Association, shall dispense funds only on order of the Commodore and shall have the financial records audited annually. The Treasurer is responsible for all financial reports, the budget, dues collection, Rebel Rabble billing, new membership activation and all other duties pertaining to such an office.

f. The Past Commodore shall be responsible for membership.

2. Four (4) Fleet Representative members of the Board of Directors shall be elected each year and shall serve for a term of two (2) years. The nominating committee shall strive to have a representative from each fleet as current continuing Board members or nominees for vacancies scheduled to occur. In the event an active fleet elects not to nominate a candidate from their fleet, the Board position shall remain unfilled. The Fleet Representative members of the Board of Directors shall be elected at the Annual Meeting and National Championship Series and shall serve until the next Annual Meeting or until their successors qualify.

3. One (1) Class Measuring Committee member shall be elected each year and shall serve for a term of three (3) years. The Class Measuring Committee members shall be elected at the Annual Meeting and their term expires after the appropriate Annual Meeting and National Championship Series, or until

their successors qualify. The Class Measuring Committee shall oversee all matters concerning measurement and specifications. The Chairman of the Class Measuring Committee shall be the member serving the third year of the member's incumbency.

4. Method of Election:

a. At least forty (40) days prior to each Annual Meeting, the Nominating Committee (as provided in Article X) shall name at least one (1) candidate for each of the aforementioned offices.

b. The names of the candidates and the offices to which they were nominated by the Nominating Committee shall be filed with the Secretary and the Secretary shall notify the membership of the Association of such nominations at least thirty (30) days prior to each Annual Meeting by mailing the same to all Active Members.

c. Any Active Member of the Association may be nominated as a candidate for any of the offices to be filled at the Annual Meeting by a petition signed by not less than ten (10) Active members.

d. All petitions shall be filed with the Secretary at least twenty (20) days prior to each Annual Meeting and he or she shall notify the membership of the Association at least fifteen (15) days prior to each Annual Meeting in a manner provided for in this Article.

e. Each Active Member may cast a vote for each office to be filled or may grant his or her proxy, pledged or unpledged, to any other Active Member on a form prescribed by the Executive Committee. The candidate receiving the greatest number of votes shall be considered elected.

### **ARTICLE IX - District Officers**

A District Commodore and District Secretary may be elected by a vote of the Active Membership in each District. Each District may establish its own method of election or appointment and term of office.

1. District Commodore shall have general supervision over all proper Rebel Class activities in the District and shall work to sustain existing fleets, and to promote new fleets and membership growth in the District.

2. District Secretary shall handle all correspondence and details of minutes, records, Fleets, membership and yachts and perform all other duties pertaining to such office. The Secretary shall automatically become District Commodore for the unexpired term should that office be vacated.

### **ARTICLE X - Board of Directors**

The Board of Directors shall consist of all Executive Officers, the immediate Past Commodore, the eight (8) Fleet Representatives, the Chairman of the Class Measuring Committee, the Editor of the Rebel Rabble and a representative of the manufacturer of the Rebel Class sailboat. The Board of Directors shall serve through the next Annual Meeting and the National Championship Series, or until their successors qualify.

Five (5) members of the Board of Directors shall constitute a quorum. Majority vote shall decide all questions before the Board if not otherwise stipulated. The Chairman shall vote only in case of a tie. The Board of Directors shall interpret the Constitution and Bylaws and may pass new Bylaws not conflicting with the existing Bylaws or Constitution. It shall conduct all business and determine policy of the Association, is the last court of appeal on disputes over Constitutional Rights, has the power to enforce its decisions by suspension of Fleet or members, and shall establish dues. The Board of Directors ruling shall be binding and final. The following committees shall be appointed by the Board of Directors and shall serve through the next Annual Meeting and the National Championship Series or until their successors qualify.

1. The Executive Committee: A sub-committee of the Board of Directors empowered to act in the name of the Board of Directors in matters requiring prompt action and personal discussion. It shall consist of the Commodore, who shall be chairman, the Secretary or the Rear Commodore and one member of the Board of Directors, who shall be appointed by the Commodore. It shall sanction or ban races, grant charters, create and alter territorial limits, fill vacancies in offices, impeach Officers and Directors (subject to ratification by three-fourths (3/4) vote of the Board of Directors), suspend members guilty of gross violations of rules or unsportsmanlike conduct for a period not exceeding its term of office, approve the purchase and sale of securities and approve depositories. The Executive Committee may appoint officers or committees which shall serve through the next Annual Meeting. These may be appointed at any time and may include a Development Committee to be in charge of developing new fleets, and special officers or committees including Rebel Race Committees for sanctioned events. The Executive Committee oversees the financing and issuance of the Rebel Rabble.

2. National Race Committee: The National Race Committee shall consist of the Vice Commodore, who will act as the chairman, the Chairman of the Class Measuring Committee, three (3) other members and one member appointed by the local hosting Fleet or Club. It shall serve until twenty-four hours after the last race or sail-off of the Series.

The National Race Committee shall conduct the National Championship Series, generally supervise all other officials and committees connected therewith and appoint the Race Committee that shall conduct each race. During this period it shall preempt the Board of Directors in matters concerning this Series, having direct and final appellate jurisdiction over all matters directly connected with the current Series, excepting disqualification of the contestants by the Race Committee. Appeals of the Race Committee decisions may be made to the United States Sailing Association (USSA) using the United States Sailing Association prescribed procedures for doing so. A majority of those members of the National Race Committee present shall decide all questions.

3. The Budget Committee: The Commodore, Vice Commodore and the Treasurer shall prepare and publish a budget for the ensuing fiscal year.

4. The Membership Committee: The Membership Committee shall consist of the immediate Past Commodore and other individuals as appointed. The Committee shall ensure that the membership roster

is maintained on a current basis. The Committee shall put forth every effort to promote and expand membership of the Association. The Committee shall supply such membership information to the National Officers and representation of the local fleets as may be reasonably requested.

5. Nominating Committee: The Nominating Committee shall consist of five (5) Active Members. The Nominating Committee must be appointed in sufficient time to prepare a list of candidates as required in Article VIII. The Nominating Committee shall present at least one (1) candidate for each office listed in Articles VIII.

## **ARTICLE XI - Meetings**

1. The Annual Meeting shall be held during and in the vicinity of the National Championship Series.

Special meetings shall be held at the order of the Board of Directors or upon demand in writing by twenty five percent (25%) of the Fleets. The exact time and place of all meetings shall be fixed by the Executive Committee.

2. Notice shall be sent to the last recorded Fleet Captain or Fleet Secretary of each Fleet and to all Active Members in time to permit action by delegate or proxy, and if special meeting, the purpose thereof must be stated in such form as to permit voting by mail and no other business can be transacted.

3. A meeting shall be held each spring, which shall have the status of a Regular Meeting.

## **ARTICLE XII - Quorum and Roll Call**

1. Twenty-five percent (25%) of the Fleets in good standing constitute a quorum at meetings.

2. If a quorum exists at roll call, it exists throughout the session.

## **ARTICLE XIII - Voting**

1. All members may be heard but only Active Members shall vote on matters coming before the membership at Annual, Regular, or Special Meetings. A vote may be cast in person, or a proxy representing that vote may be granted, pledged or unpledged, to any other Active Member on a form prescribed by the Executive Committee.

2. A majority of the votes present shall decide all questions not otherwise stipulated and the chair shall cast the one deciding vote in case of a tie and may also fix a time limit on speakers and motions.

## **ARTICLE XIV - Expulsion**



A member may be expelled only by a three-fourths (3/4) vote at an Annual Meeting. (Impeachment of Officers - See Article X - Section 1).

### **ARTICLE XV - Amendments**

1. The Constitution can never be suspended, but may be amended at any Annual, Regular or Special Meeting by two-thirds (2/3) of the votes.

2. Two (2) copies of the proposed amendment signed by the proposers, who shall be not less than twenty-five (25) Active Members, shall be delivered to the Association Secretary at least forty (40) days prior to the date of the meeting at which it is to be considered. All proposed amendments at either Annual, Regular or Special Meetings must be included in the notice of the meeting and shall be mailed not less than thirty (30) days prior to the date of the meeting.

3. The basic principles of Articles III, IV, and VI cannot be changed nor can an amendment be passed which will render ineligible a former yacht or Active Member whose eligibility was established under then existing rules of this Association and whose status cannot be changed to conform to the proposed amendments, nor shall retroactive legislation be passed affecting Active Members' or Fleets' Constitutional Rights.

4. The Executive Committee shall have the power to simplify, clarify or correct the wording of any article without changing its intent or purpose.

### **ARTICLE XVI - Dissolution**

The term for which this Association shall exist shall be perpetual. If this Association is ever dissolved, the residual assets will be turned over to one or more organizations which themselves are exempt as organizations described in Sections 501(c)(3) and 170(c)(2) of the Internal Revenue Code of 1954 or corresponding sections of any prior or future Internal Revenue Code or to the federal, state or local government for exclusive public purpose.

# **BYLAWS**

## **ARTICLE I - DUES**

1. Dues for both Active and Associate Members shall be established by the Board of Directors and may be changed only by them, and may be done so only in accordance with Article X of the Constitution.

2. Dues are payable by April 30. A member who has not paid his dues by this time shall be considered not in good standing. If new members pay dues between October 1st and January 1st, such dues shall apply to the following year.

## **ARTICLE II - Renewal of Charter**

1. Each Fleet is required to file an annual report with the Association each year in order to renew its rights and privileges under its charter.

2. If the annual report of a Fleet has not been received by the Association on or before December 1 of the same year it becomes automatically suspended.

3. Suspended Fleets and Members, and ineligible yachts may be posted by publication and cannot be reinstated until all requirements of the Association have been fulfilled.

## **ARTICLE III - Eligible Yachts**

A yacht is eligible and considered in the Rebel Class only if it conforms to the measurement rules, has been properly registered and is owned by a qualified Active Member recorded at the time as in good standing in the Association.

## **ARTICLE IV - Racing Rules**

The official Code of Racing Rules which shall govern all Rebel Class races held by the Association, unless otherwise specified, shall be that of the United States Sailing Association (USSA). Entrance fee for the Annual National Regatta shall be established by the Board of Directors and shall be paid to the Host Fleet who shall transmit such fees to the Association in accordance with the prescribed rules as set forth by the Board of Directors.

## **ARTICLE V - Racing Restrictions**

1. Numbers must be displayed on both sides of mainsail, in letters not less than ten (10) inches high.

2. The number of persons allowed in one boat, in a race, shall be no less than two (2). In a race series, the number of persons in a boat in the first race must be maintained in the succeeding races.

3. All members of crews sailing in the National Championship Series or any other sanctioned regatta shall be Active Members, their children (under 18 years of age or full time students under 22 years of age), Associate or Honorary Members and Corinthians.

4. A member shall be in good standing before the close of registration at the National Championship Series in order to be permitted to skipper in the Series.

5. No dead weight can be carried as stationary or shifting ballast, except stationary weight as may be required to meet minimum total weight requirements.

6. No sails other than approved jib and mainsail can be used and not more than three (3) complete suits of sails shall be measured at any sanctioned event requiring the measurement of sails, but only two (2) complete suits of sails shall be approved. Once a sail has been officially measured, it need not be subsequently re-measured, provided the owner verifies that no modifications have been made since it was officially measured.

7. A yacht must carry ground tackle of serviceable character for the locality as approved by the Race Committee, an approved life preserver for each person in the boat, adequate bailing equipment, a paddle or an oar and an approved throwable device.

8. Sculling with rudder is prohibited. Sweeping boats head around to change course or fall away is not considered sculling.

9. Once a yacht has been officially weighed, measured, and approved, it need only be re weighed every second calendar year, provided the owner and skipper verify that no modifications which could affect proper compliance of the yacht to the Rebel Class specifications have been made since it was last officially weighed and measured, and approved.

## **ARTICLE VI - Interpretation**

In deciding any question, the intended meaning of the rules shall be considered rather than any technical misconstruction that might be derived from the wording. Extenuating circumstances cannot be taken into consideration insofar as racing rules are concerned if there is an actual foul, but may be taken into consideration in class rules or restrictions if the wording requires interpretation and no deliberate attempt to gain an unfair advantage has been practiced. Rulings of the Executive Committee, the Board of Directors, the National Race Committee and the Measuring Committee shall be carefully preserved for reference.

## **ARTICLE VII - Sanctioned Events**

Any open event in which all of the following requirements are met:

1. At least two (2) races shall comprise the event.
2. A minimum of five (5) boats shall start in the initial race of an event and if this requirement is met, at least this total shall be presumed to have started in the remaining races of an event.

3. At least three (3) National Rebel Class Association recognized Fleets, or all Fleets within the District are represented as racing participants.

4. It is endorsed by the Executive Committee of the National Rebel Class Association.

5. All Series for major Rebel Championship territorially greater than one Fleet, or events for perpetual, semiperpetual or open trophies must be sanctioned by the Fleet on whose waters the event is held, if an intra-fleet event, and by the Association's Executive Committee if inter-fleet event. The Executive Committee may outlaw any event for cause.

6. Only Active Members (and family as provided for in Article V, Section 4) may skipper boats in sanctioned events except that a non-owner renting or borrowing a Rebel Class sailboat for the major portion of the racing season may, upon application to the Board of Directors, be granted permission to skipper a Rebel Class sailboat in sanctioned events providing that the non-owner submits an affidavit verifying that he or she has rented or borrowed the boat for the major portion of the racing season and that the non-owner pays Active Membership dues. Only Active Members or Associate Members may crew in a sanctioned event.

7. The Association shall not be held financially responsible for any sanctioned event.

### **ARTICLE VIII - Limitation Governing Purchase of Sails**

The acquisition of new suits of sails by Rebel Class sailboat owners shall be limited to one (1) suit in any year, except that one (1) additional suit may be acquired for any boat during its first sailing season, unless the owner already has in his possession one or more suits of sails at the time of acquiring the yacht.

### **ARTICLE IX - Class Publications**

The "**Rebel Rabble**" shall be the official publication of the Association and shall be issued and financed by the Association as directed by the Executive Committee.

### **ARTICLE X - Specifications**

1. Explanations - Specifications, however complete cannot anticipate every possible situation that may arise. If a point is not herein covered, a ruling must be obtained from the Board of Directors or a committee designated by it. In interpreting any point not covered, or wording of obscure meaning, the intended meaning shall be considered rather than any technical misconstruction that might be derived from the wording, and the basic principle of the specifications, which is to maintain the Rebel Class sailboat as a standard one-design class, shall be borne in mind at all times.

a) Effective July 8, 1989, no hull, deck or tank modifications will be made to existing Rebels without written approval of the Measurement Committee.

b) No post production hull, deck or tank modifications will be made to any Rebel built after July 8, 1989.

2. Requirements - A yacht, its spars, rigging, and sails must conform strictly throughout with respect to design, dimensions, construction and material to the official plans and specifications of the National Rebel Class Association to be considered a Rebel and be eligible to the Rebel Class. For those boats and sails made after March 15, 1990, only those on which a royalty or number tax has been paid to the National Rebel Class Association shall be eligible to meet these Specifications. Nothing is optional in these specifications unless the word "optional" appears in the article and then only within the limitations described.

### 3. Hull Dimensions:

a. Length overall - 16 feet 1 and 1/4 inches (16' 1-1/4") measured from transom to stem.

b. Greatest beam - 6 feet 7 and 1/2 inches (6' 7-1/2") not including moldings.

c. All hulls must be made of fiberglass from a mold approved by the Association. The completed fiberglass hull must conform to the standard weight limitations of 700 pounds minimum with all standing rigging, flotation, mast, boom, rudder, tiller, floorboards (if used), centerboard, blocks and sheets. If this weight is less than the minimum, the difference shall be made up by the addition of any materials and permanently attached to the hull, except for the last 20 pounds. The last 20 pounds must then be wired or bolted or screwed into place. If weight must be added, the first 75 pounds may be placed as desired and, if additional weight is required, it must be placed at least 4 feet aft of the mast. The added weight does not have to be permanently attached the first year a boat sails in the National Championship Series.

d. Flotation - The boat will have sufficient flotation to float at deck level from stem to stern when the boat is filled with water.

e. The thickness of the hull must be uniform except where reinforced locally such as the keel, the stem and where the stay anchors and rudder gudgeons are attached. Localized stiffeners such as ribs to support the hull are also permitted. Supports and reinforcing may be made of materials other than fiberglass such as wood or aluminum.

### 4. Deck:

The deck may be made of fiberglass or wood with canvas covering provided the weight limitations are met and design is approved by the Association. As of March 29, 1988 decks cannot be modified from approved plans. Air tanks may be formed from seats, provided seats are not shortened more than 18 inches from the transom.

### 5. Fastenings:

Fastenings may be of any material and may be galvanized or plated.

### 6. Spars:

a. All masts and all booms manufactured or assembled for the Rebel Class sailboat after July 18, 1997 shall meet extrusion dimensions as indicated by the "Rebel Spar Section" drawing, which is a part of these Bylaws. The use of masts and booms manufactured or assembled prior to July 19, 1997, that met previous specifications, is permitted. Spar length is shown on the "Sail Plan" drawing. Extrusion "Size No 2" from Cape Cod Ship Building Co. – Zephyr Division is also approved. See drawing.

b. There shall be no restrictions as to the use, length or material of the whisker pole, except that it may be only used for the jib.

c. The mast step location shall be as shown on the Official Plan measured from the stem.

#### 7. Rigging:

a. Standing rigging shall be as shown on the plans as to position and number and length of stays, to be of wire rope of diameter and strength not less than shown on the plans. Spreaders and struts to be shown as to position, length, diameter and wall thickness. The spreaders must be horizontal to the vertical line of the mast and must not be swept aft more than 8 degrees.

b. Any change in the set of standing rigging during a race except as occasioned by accident shall be prohibited.

c. Changes in running rigging, not expressly barred in the plans or specifications may be made at the owner's option. Additional fittings to aid in ease and convenience of handling the boat may be used at the owner's option. However, a trapeze or other rigging (except hiking straps) used by the crew to utilize his or her weight to trim the boat is prohibited.

#### 8. Centerboard:

To be a maximum of 5/16 inch (5/16") thick and not vary more than 1/2 inch (1/2") in any dimension from official pattern, provided, however, that the edges may be tapered to within 1 inch (1") on the edge and that the radius along the edge shall not be less than 1/16 inch (1/16"). Centerboards shall be made of any metal and may be galvanized or plated. The weight of the centerboard shall be 110 pounds maximum.

#### 9. Rudder and Tiller:

a. The rudder shall be a minimum thickness of 1/2 inch (1/2") and a maximum thickness of 3/4 inch (3/4"), and may be tapered to not less than 1/16 inch (1/16") radius at the edges. It may be arranged to tip up when striking an underwater object, but must be kept in the full down position during races. The outline must be as shown in the official plan, but may be notched to fit existing cheek plates.

b. Rudders may be positioned to a depth not to exceed 27 and 1/8 inches (27-1/8") measured from the line from the bottom of the hull in a line approximately parallel to the front edge of the cheek plate.

The line of the bottom of the hull shall be determined by placing a straight edge flush with the bottom of the hull as near the center of the hull as possible. The straight edge shall overlap the hull by 24 inches (24") plus or minus 1/2 inch (1/2").

10. Floorboards:

May be made of any material and of any design at the option of the owner, or may be omitted entirely.

11. Sails:

a. No sails other than the jib and mainsail are allowed. Loose footed mainsails, jib booms, double luff mainsails, other than reef points or accidental, are barred. It is permissible to have multiple plastic windows in the mainsail and the jib as an aid to avoiding collisions. Total window area per sail is not to exceed 6 square feet.

b. Mainsail and jib shall be of cotton or synthetic woven fabric. The sail cloth shall not be lighter than 3.7 ounce material, this weight being based on a lineal yard 28 and 1/2 inches (28-1/2") in width. Sails may be stiffened and reinforced only with sailcloth and only to the extent permissible under USSA sail measurement instructions as follows:

"It is the essence of this instruction that sails shall be flexible, soft and capable of being easily stowed. Whether of woven or unwoven fabric, the body of the sail shall be so constructed that it can be folded flat in any direction, other than in way of windows and of corner stiffening as defined below, without cracking or otherwise permanently damaging the sail or its reinforcement. Reinforcement of any material having the effect of stiffening the sail shall be permitted only within a distance from each corner of 11 and 1/4 inches (11-1/4") for the jib and 13 and 3/8 inches (13-3/8") for the mainsail. Other reinforcement, as a continuation of corner stiffening or elsewhere, comprising not more than two additional layers of fabric of the same weight as the body of the sail is permitted unless it is stiffened by the addition of bonding agents, close stitching or otherwise, and provided that it can be folded as described above. Glued seams shall not be considered as stiffening."

Sails made prior to September 1, 1976, shall be measured under old rules with respect to stiffening close to the corners of the sail.

c. Racing number and class emblem not less than ten (10") inches high must be attached on each side of the mainsail and be of size and design shown on the official plan.

d. Sails may be reefed at the foot only. The jib, when used, must be used without reefing.

e. Battens may be of any material. There shall be four battens in the mainsail and they shall divide the leech into approximately five equal parts. The lengths of the battens shall not exceed 3 feet 4 inches (3' 4"). Battens in the jib are prohibited.

f. Size of mainsail:

The luff and foot dimensions shall be governed by the banding requirement of Section 12. The leech, measured in a straight line from top forward corner of headboard to edge of the sail at the clew, not including the bolt rope, shall be 23 feet 10 inches (23' 10") or less when stretched sufficiently to straighten out the material. Roach and draft are governed by a measurement across the sail from a point on the luff halfway from top of headboard to tack, not including the bolt rope, to a point on the leech halfway from top of headboard to clew, not including the bolt rope. This measurement shall not exceed 7 feet 3 inches (7' 3"). The size of the headboard shall not exceed 5 inches (5") across measured perpendicular to the mast.

g. Size of jib:

The luff, measured from the apex of the sail at the head and the apex at the tack, shall be 15 feet (15') or less. The foot, measured from the apex of the sail at the clew to the apex of the sail at the tack shall be 7 feet (7') or less. The leech, measured from the apex to the sail at the clew to the apex of the head shall be 13 feet 6 inches (13' 6") or less. The mid-foot measurement from the apex of the sail at the head to a point on the foot halfway between the apexes to the tack and clew shall not exceed 14 feet 6 inches (14' 6"). Sails manufactured or reworked prior to July 11, 1976, are exempt from the mid-foot measurement. These measurements shall be made with approximately 5 pounds pull on the sail. The apex of the head shall be 4 inches (4") above two points where the sail before the leech is 1 and 31/32 inches (1-31/32") from luff to leech. The sail luff and leech shall be measured by positioning it between these points such that the leech touches one and the luff touch the other. The apexes of the tack and clew are defined by the triangle formed by the edges of the cloth at the luff, the leech and a straight line from the tack to the clew (excluding notches and cutouts).

12. Banding:

Bands at least 1/2 inch (1/2") wide shall be affixed to the mast and boom to mark the maximum allowable positions of the three corners of the main sail. The measurement from outside edge to outside edge of the top and bottom bands on the mast shall not exceed 22 feet 3 and 1/2 inches (22' 3-1/2"). The measurement along the boom from the aft edge of the mast to the outside edge of the band on the boom shall not exceed 11 feet 1 and 1/2 inches (11' 1-1/2"). Alternate sets of bands on the mast may be used providing they are of contrasting color and meet the above dimensional requirements.

## **ARTICLE XI - Amendments to Bylaws**

1. Bylaws of the Constitution (except for Article X) may be amended by either of the following:
  - a. By a majority vote of the entire Board of Directors at either Annual, Regular or Special Meeting.



b. By a majority vote of the membership present at the Annual Meeting after submitting a written petition with the signatures of ten (10) active Members prior to the start of the meeting.

2. Article X, Specifications, may be amended as provided in Article XI, (1) above except that the proposed amendment must be included in the notice of the meeting and shall be mailed not less than fourteen (14) days prior to the date of the meeting.

SAIL PLAN

16' REBEL

LOA- 16' 1 1/4"  
 BEAM- 6' 7 1/2"  
 DRAFT- 3' 6"  
 SAIL AREA- 166 SQ. FT. MAX.

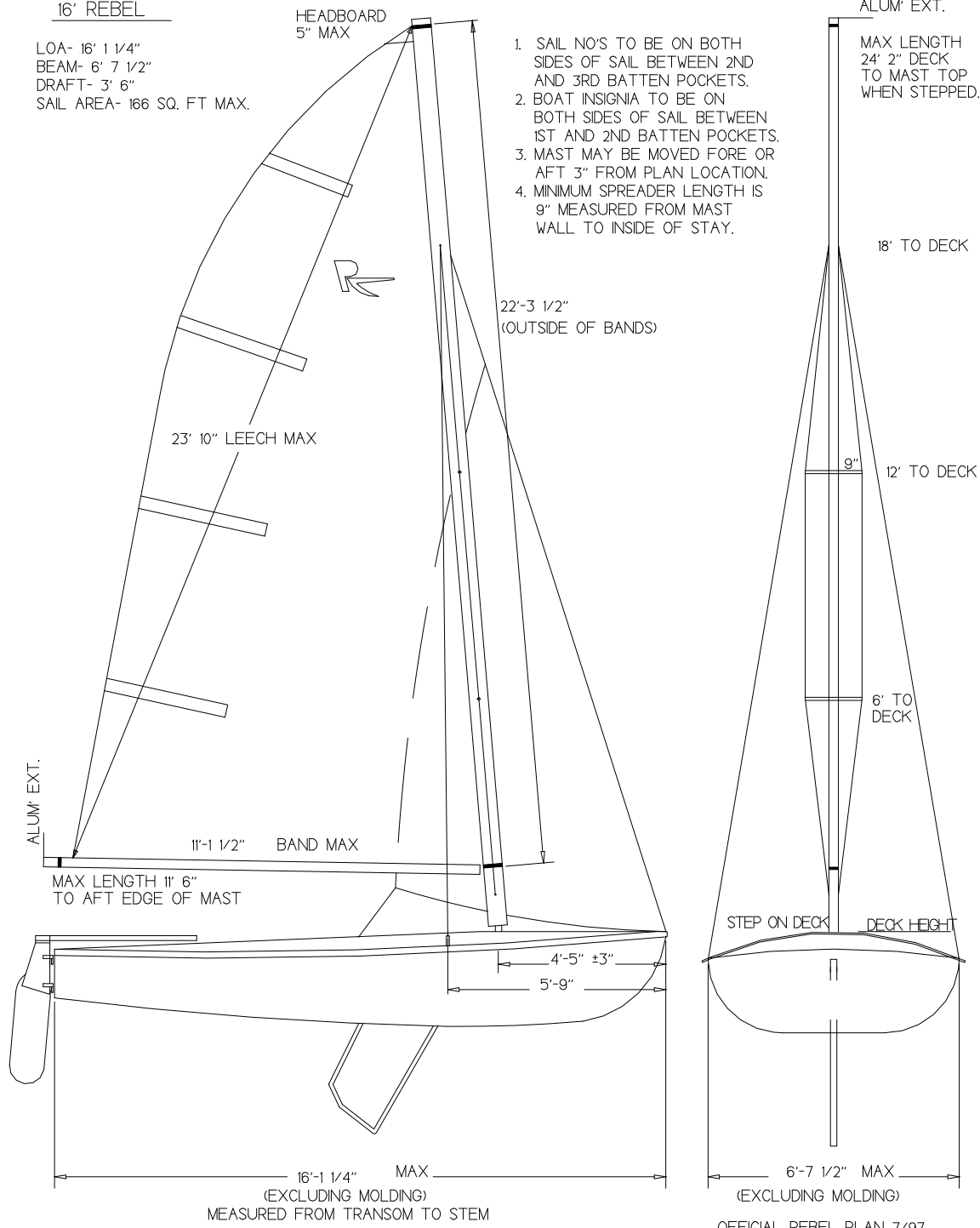

## CENTERBOARD AND RUDDER SPECIFICATIONS

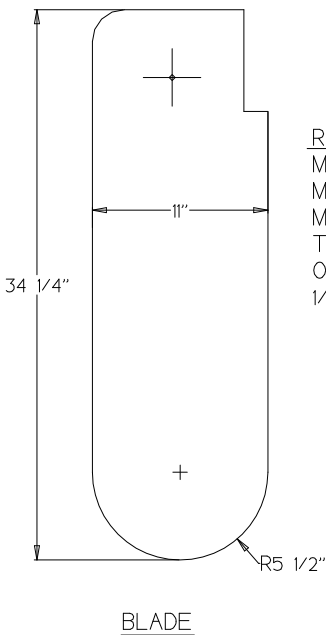

TILLER LENGTH, MATERIAL AND HIKING STICK OPTIONAL

RUDDER BLADE  
 MATERIAL- OPTIONAL  
 MIN THICKNESS- 1/2  
 MAX THICKNESS- 3/4  
 TOLERANCE WITHIN 1/4"  
 OF PATTERN DIMENSIONS  
 1/16" MIN EDGE TAPER THICKNESS

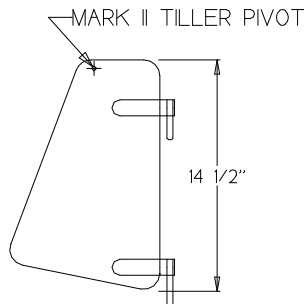

RUDDER CHEEK PLATES  
 (2) REQ'D  
 MATERIAL- 3/16 ALUMINUM  
 LIGHTENING HOLES ALLOWED  
 DIMENSIONS ARE REFERENCE ONLY  
 PLACEMENT OF GUDGEONS  
 AND PINTLES OPTIONAL

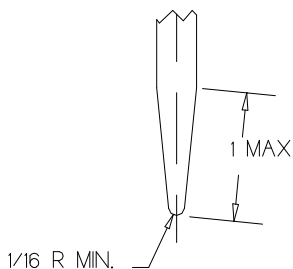

SEC A-A

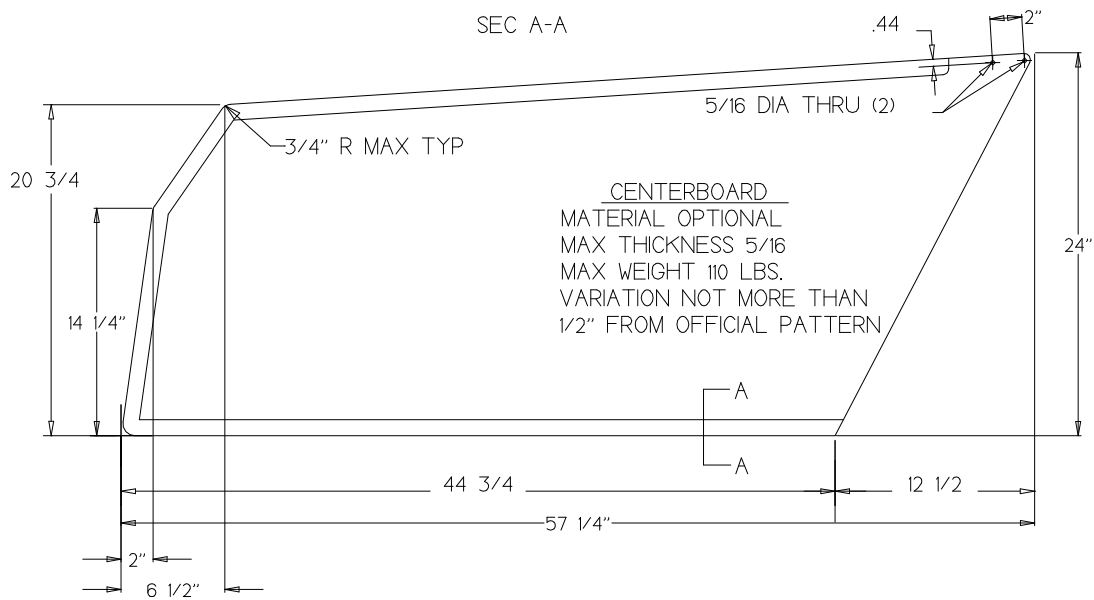

CENTERBOARD  
 MATERIAL OPTIONAL  
 MAX THICKNESS 5/16  
 MAX WEIGHT 110 LBS.  
 VARIATION NOT MORE THAN  
 1/2" FROM OFFICIAL PATTERN

CENTERBOARD

OFFICIAL REBEL PLAN 7/97

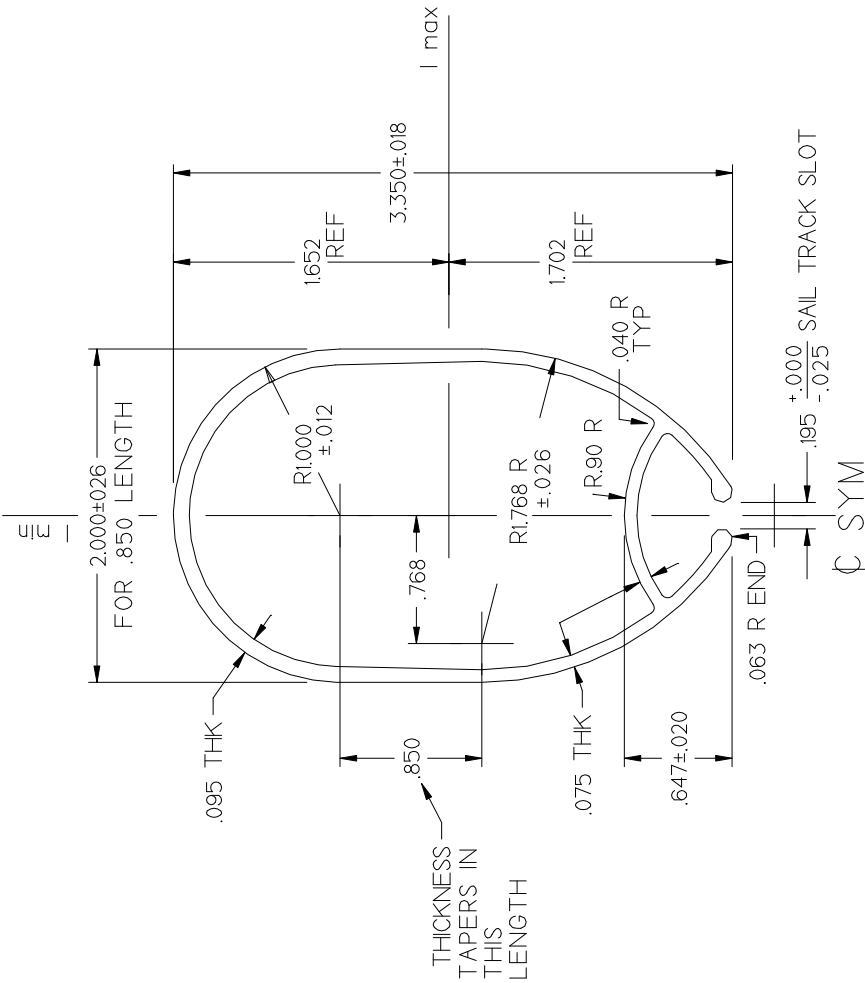

AREA (in <sup>2</sup> )	.797
l <sub>max</sub> (in <sup>4</sup> )	.969
l <sub>min</sub> (in <sup>4</sup> )	.409
Y/cf (in <sup>3</sup> )	.569
Y/cs (in <sup>3</sup> )	.409
Weight (Lb) for 24'	22.5

THICKNESS TOL ±.005  
 STRAIGHTNESS .012"/FT  
 TWIST 1/4"/FT (5° MAX)  
 TOLERANCES ±.30

COMPUTER GENERATED DRAWING  
 NO HAND CHANGES

REBSPAR3.GCD

CHANGE	DATE	NAME		DWG. SIZE
		SECTION - REBEL SPAR		A
		MATERIAL	SCALE	DRAWN
		ALUMINUM		NEROBB
		ALLOY		7FEB93
		6061-T6	PART NUMBER	
SAIL TRACK WAS .16 ±.01		NICKELS BOAT WORKS		
REVISED TOL & NOTES		2426 S LONG LAKE RD		
PRODUCTION RELEASE		FENTON, MI		
		48430		
		LIMITS UNLESS SPECIFIED	ANGLES ±	2 PLC DEC ± .020
			4 PLC DEC ± .	3 PLC DEC ± .010

## Size No. 2

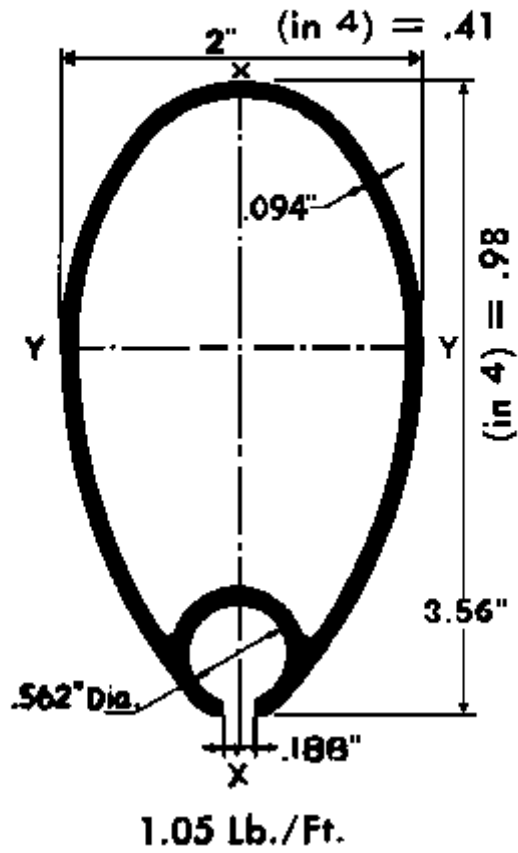

Cape Cod Ship Building Co. - Zephyr Division  
Mast Section Approved April 12, 2015

REBEL CLASS EMBLEM

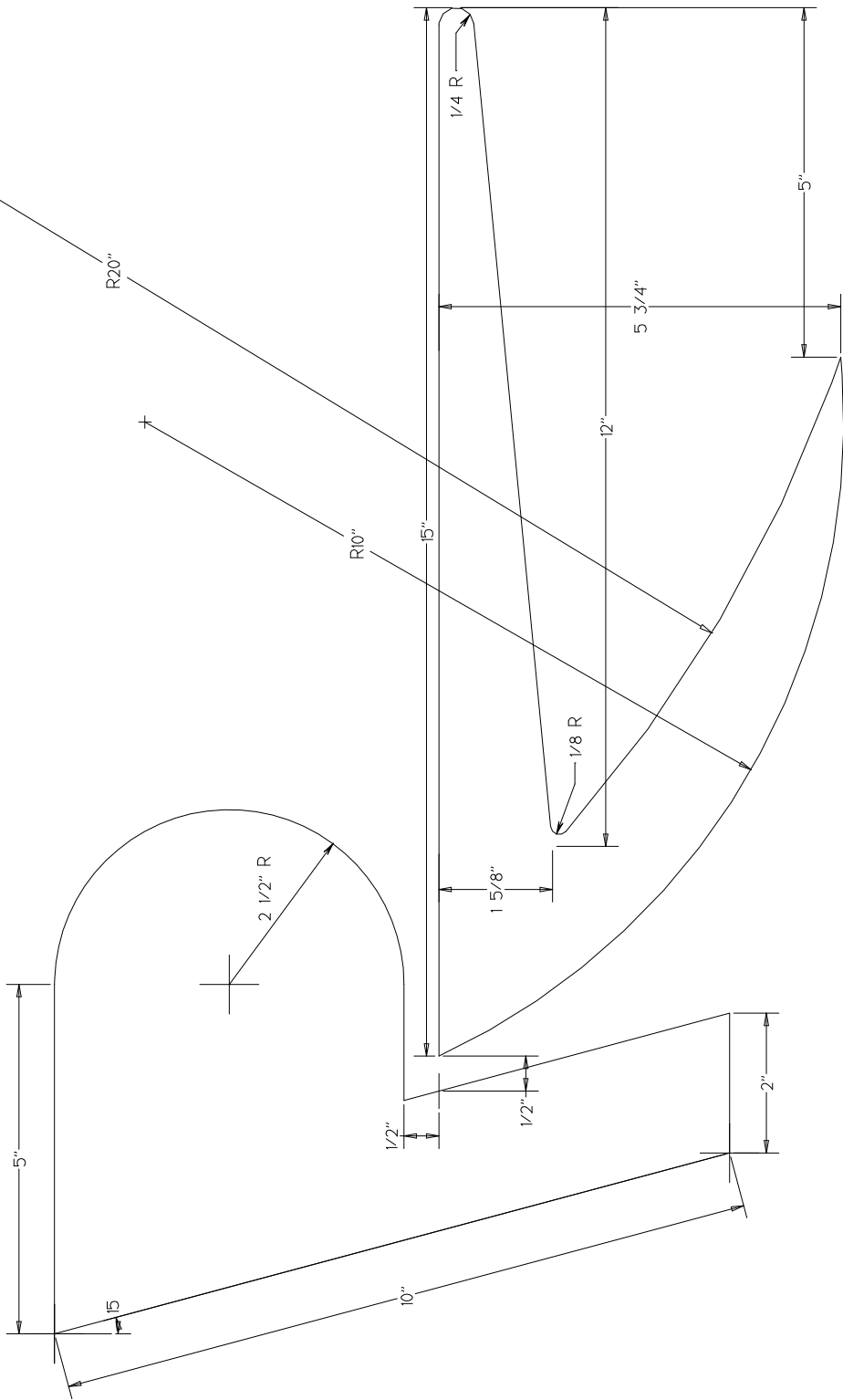

OFFICIAL REBEL PLAN 7/97